



# 850nm Multi-mode Transceiver

## QSFP56 form factor with Diagnostic Monitoring

### 200GBASE QSFP56 AOC Breakout 1X2 Transceiver

## B2BQFP4CXXBC-XX0

### Features

- Supports IBTA InfiniBand HDR
- 200Gb/s HDR to 2x100Gb/s HDR100 data rate
- 4x 50Gb/s PAM4 modulation
- SFF-8665 compliant QSFP56 port
- SFF-8636 compliant I2C management
- Single 3.3V power supply
- Max 4.5W power dissipation each end, with retiming
- Operating case temp Commercial: 0°C to +70 °C
- Hot pluggable
- RoHS compliant

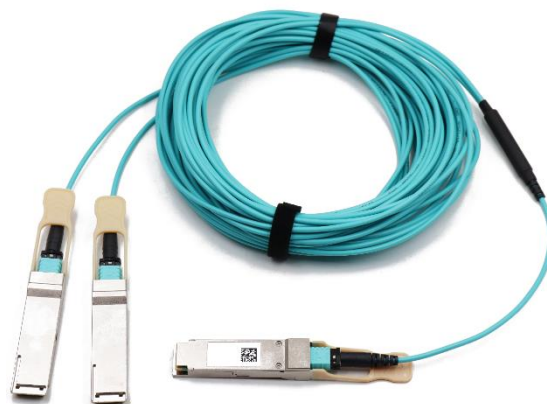

### Applications

- 200Gb/s InfiniBand HDR systems
- Other optical links

### Order Information

Table 1-Order Information

Part No.	Bit Rate (Gbps)	Wavelength (nm)	Distance	Fiber Type	DDMI	Temp <sup>note1</sup>
B2BQFP4CXXBC-XX0	4x50	850	1~50m	MMF	YES	0°C~+70°C

Note1: Case Temperature



## Absolute Maximum Ratings

Table2- Absolute Maximum Ratings

Parameter	Symbol	Min.	Typical	Max.	Unit	Notes
Supply Voltage	V <sub>CC3</sub>	-0.5	-	+3.6	V	
Storage Temperature	T <sub>s</sub>	-5	-	+75	°C	
Operating Humidity	RH	+5	-	+85	%	1

Note1: Non condensation

## Recommended Operating Conditions

Table 3- Recommended operating Conditions

Parameter	Symbol	Min.	Typical	Max.	Unit	Notes
Operating Case Temperature	T <sub>C</sub>	0	-	+70	°C	
Power Supply Voltage	V <sub>CC</sub>	3.14	3.3	3.47	V	
Power dissipation (200G retiming on all lanes)	P <sub>d200G</sub>	-	-	4.5	W	1
Power dissipation (100G retiming on all lanes)	P <sub>d100G</sub>	-	-	2.5	W	1

Note1: Per terminal



## Electrical Characteristics

Table 4- Electrical Characteristics

Parameter	Symbol	Unit	Min	Typ	Max	Notes
<b>Transmitter</b>						
Signaling rate (each lane)	SR	GBd	26.5625 ± 100 ppm			
Differential data input voltage per lane	V <sub>in,pp,dif</sub> f	mV	900	-	-	
Differential termination mismatchal	-	%	-	-	10	
Single-ended voltage tolerance range	-	V	-0.4	-	3.3	
DC common mode voltage	-	mV	-350	-	2850	
<b>Receiver</b>						
Signaling rate (each lane)	SR	GBd	26.5625 ± 100 ppm			
Differential output voltage	-	mV	-	-	900	
Differential termination mismatch	-	%	-	-	10	
Transition time (min, 20% to 80%)	-	ps	9.5	-	-	
DC common mode voltage	-	mV	-350	-	2850	
Error Bit Rate	BER	-	-	-	2.4E-4	Note1

Note1: PRBS31Q@26.5625Gbd PAM4

## Recommended Interface Circuit

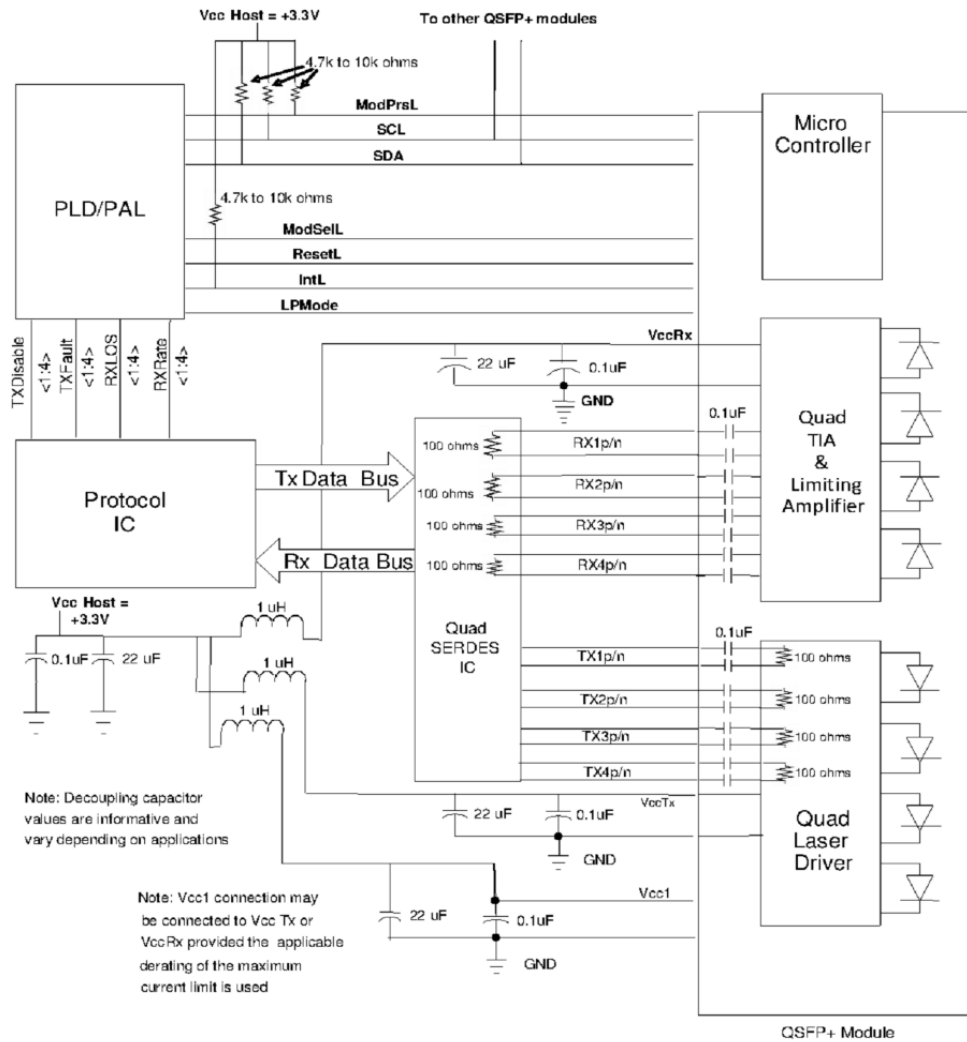

Figure 1 Recommended Interface Circuit

## Pin arrangement

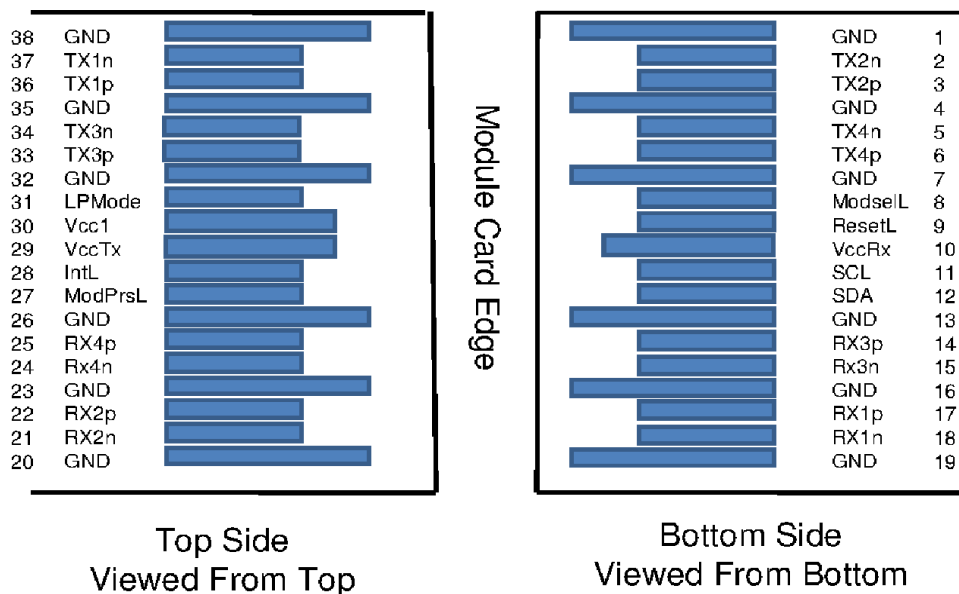

Figure 2 Pin View

Table 5-Pin Function Definitions

Pin	Symbol	Name/Description	Notes
1	GND	Ground	1
2	Tx2n	Transmitter Inverted Data Input	
3	Tx2p	Transmitter Non-Inverted Data Input	
4	GND	Ground	1
5	Tx4n	Transmitter Inverted Data Input	
6	Tx4p	Transmitter Non-Inverted Data Input	
7	GND	Ground	1
8	ModSelL	Module Select	
9	ResetL	Module Reset	
10	Vcc Rx	+3.3V Power Supply Receiver	
11	SCL	2-wire serial interface clock	
12	SDA	2-wire serial interface data	
13	GND	Ground	1
14	Rx3p	Receiver Non-Inverted Data Output	
15	Rx3n	Receiver Inverted Data Output	
16	GND	Ground	1



**850nm Multi-mode Transceiver**  
**QSFP56 form factor with Diagnostic Monitoring**  
**200GBASE QSFP56 AOC**

17	Rx1p	Receiver Non-Inverted Data Output	
18	Rx1n	Receiver Inverted Data Output	
19	GND	Ground	1
20	GND	Ground	1
21	Rx2n	Receiver Inverted Data Output	
22	Rx2p	Receiver Non-Inverted Data Output	
23	GND	Ground	1
24	Rx4n	Receiver Inverted Data Output	
25	Rx4p	Receiver Non-Inverted Data Output	
26	GND	Ground	1
27	ModPrsL	Module Present	
28	IntL	Interrupt	
29	Vcc Tx	+3.3V Power supply transmitter	
30	Vcc1	+3.3V Power supply	
31	LPMODE	Low Power Mode	
32	GND	Ground	1
33	Tx3p	Transmitter Non-Inverted Data Input	
34	Tx3n	Transmitter Inverted Data Input	
35	GND	Ground	1
36	Tx1p	Transmitter Non-Inverted Data Input	
37	Tx1n	Transmitter Inverted Data Input	
38	GND	Ground	1

**Note1: Circuit ground is internally isolated from chassis ground.**



**850nm Multi-mode Transceiver**  
**QSFP56 form factor with Diagnostic Monitoring**  
**200GBASE QSFP56 AOC**

## Monitoring Specification

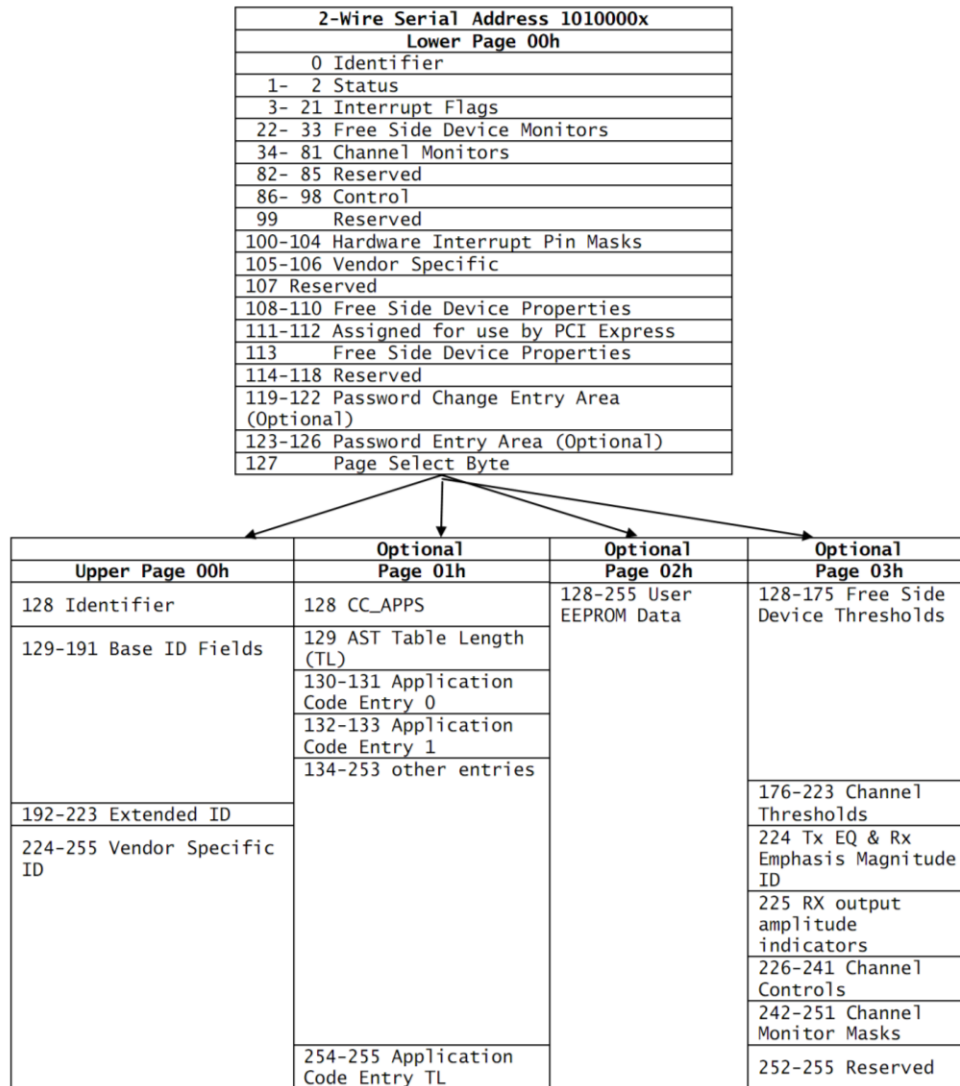
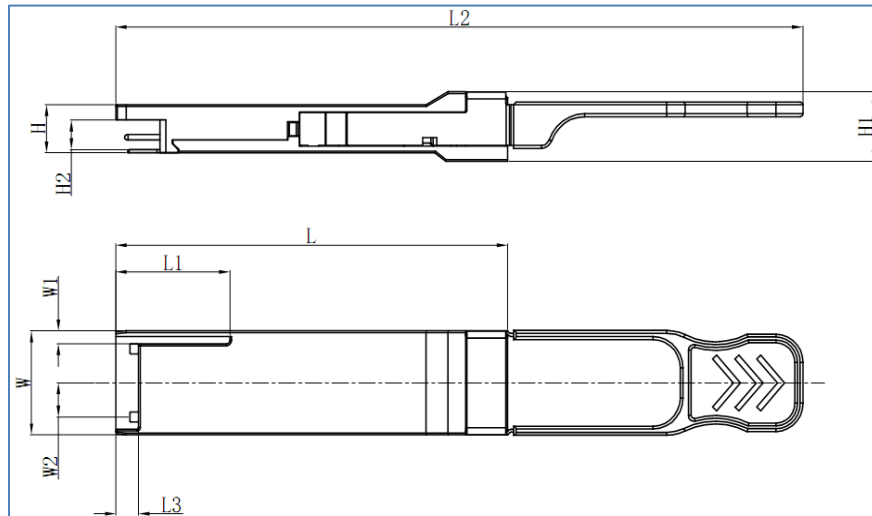

Figure 3 Memory Map

### Mechanical Dimension



Unit mm

	L	L1	L2	L3	W	W1	W2	H	H1	H2
Max	72.2	-	128	4.35	18.45	-	6.2	8.6	12.0	5.35
Type	72.0	-	-	4.20	18.35	-	-	8.5	11.8	5.2
Min	68.8	16.5	124	4.05	18.25	2.2	5.8	8.4	11.6	5.05

Figure 4 Mechanical Diagram of Per Terminal

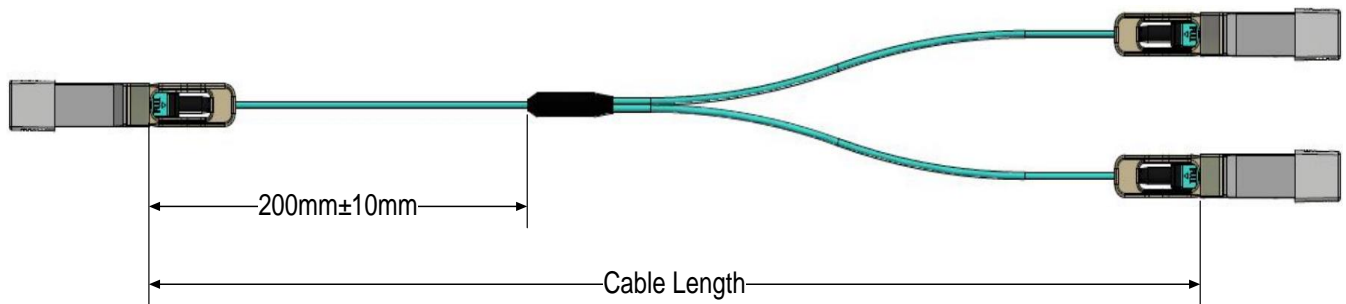

Figure 5 Mechanical Diagram of Cable





**850nm Multi-mode Transceiver**  
**QSFP56 form factor with Diagnostic Monitoring**  
**200GBASE QSFP56 AOC**

---

**Table 6: Cable Length**

Parameter	Value	Units
Diameter	3±0.2	mm
Minimum bend radius	30	mm
Length tolerance	1 m ≤ length ≤ 4.5 m: +15 / -0	cm
	5 m ≤ length ≤ 14.5 m: +30 / -0	cm
	Length ≥ 15.0 m: +2% / -0	m
Cable color	Aqua	

**Table 7: Connectivity Schematic**

200Gb/s Side	100Gb/s Side
	<b>Port 1</b>
TX1	RX1
RX1	TX1
TX2	RX2
RX2	TX2
	<b>Port 2</b>
TX3	RX1
RX3	TX1
TX4	RX2
RX4	TX2



## LABEL SPECIFICATIONS

26.7 mm x 14.7 mm

Example: 200G side



100G side port 1:



100G side port 2:



Figure 6 Component Label



**850nm Multi-mode Transceiver**  
**QSFP56 form factor with Diagnostic Monitoring**  
**200GBASE QSFP56 AOC**

---

**Table 8 Label Description**

Note 1	Serial Number	YMDDLXXXZ (ex. NC2501001A) Y: year of manufactured (ex. 9 = 2009, A = 2010, ..., N = 2023, ...) M: Month of manufactured (1~9 for Jan.~Sep., A for Oct., B for Nov., C for Dec.) DD: Day of manufactured LL: Last 2 codes of APAC manufacture order sequency number XXX: Running number (3 digits sequential number from 001 to 999) Z: A for the 200G QSFP56 side, and B and C for the other side of two 100G QSFP28.
Note 2	Manufacture Location	Made in Taiwan



**850nm Multi-mode Transceiver**  
**QSFP56 form factor with Diagnostic Monitoring**  
**200GBASE QSFP56 AOC**

---

## REVISION HISTORY

Rev.	Date	Note
1.0	2021/04/23	New released
1.1	2024/04/08	Change Label dimension

For sales and support in your region, please go to [sales@apacoe.com.tw](mailto:sales@apacoe.com.tw)